

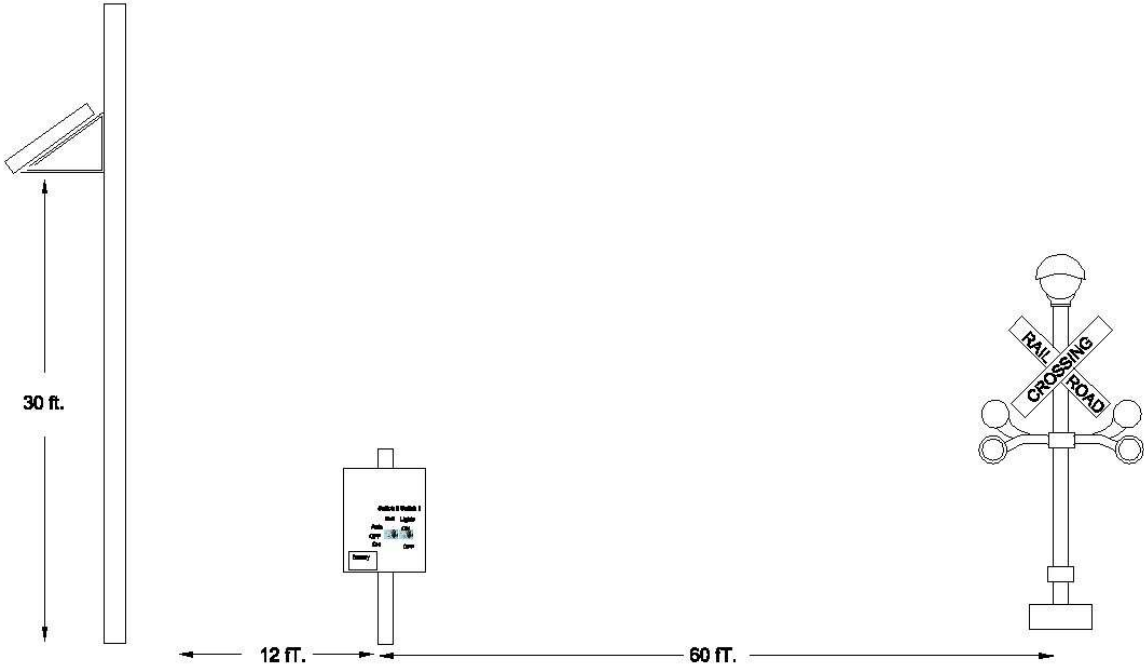

Signal at the Parking Lot entrance. Revised 9-24-24

The grade crossing signal at the entrance to the parking lot is controlled by the signal box located about 60 feet west of it. The signal box contains the 12-volt battery and the control electronics for the crossing signal. There is a solar panel mounted on a tree to keep the battery charged.



The power and control system housed in signal box has no operational controls. There is no reason to enter the signal box for normal operation of the signal.

To turn the signal on, remove the lock and let the door hang open.

To turn off the signal close and lock the door.

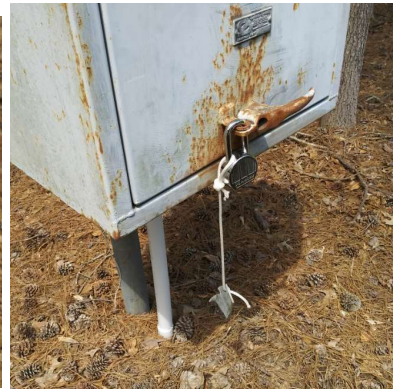

Details:

The system is composed of a battery, a timer chip and a lamp driver module. The timer chip provides the pulses to the lamp driver module to cause the lights to flash. These three components are housed in the signal box and are connected to the crossbuck signal via three wires through an underground conduit.

To reduce the power requirements, the original incandescent 12-volt lamps used in the crossing signal were replaced with red 12-volt LED assemblies that are used in automobiles.

Additionally, there is a solar panel charging system connected to the unit. If the cables are disconnected from the battery, no charging will take place.

The interlock switch on the door, switches the power to the system on and off as the door is opened and closed.

The system was initially configured with a Lead Acid battery to provide the power.

In 2024, the system was changed and now provides the power from a Lithium-Ion battery pack.

The Lead Acid Charging module was replaced with an LM2596 Buck Regulator module set to 12.40 volts.

The charger supplied with the Li-Ion battery, charges it to 12.8 volts.





Z

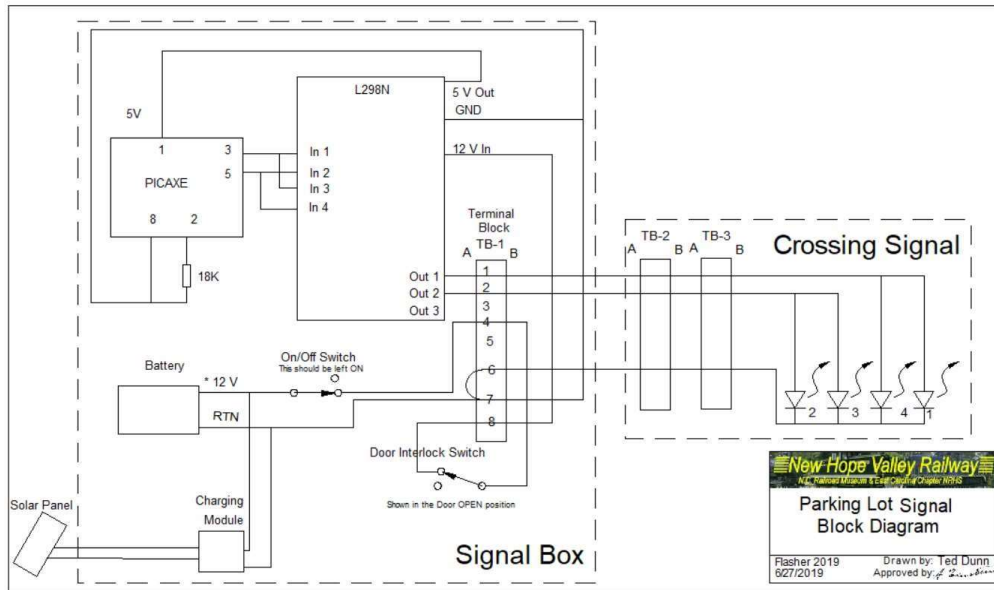

The system was modified to use a Lithium-Ion battery pack instead of the Lead Acid battery.

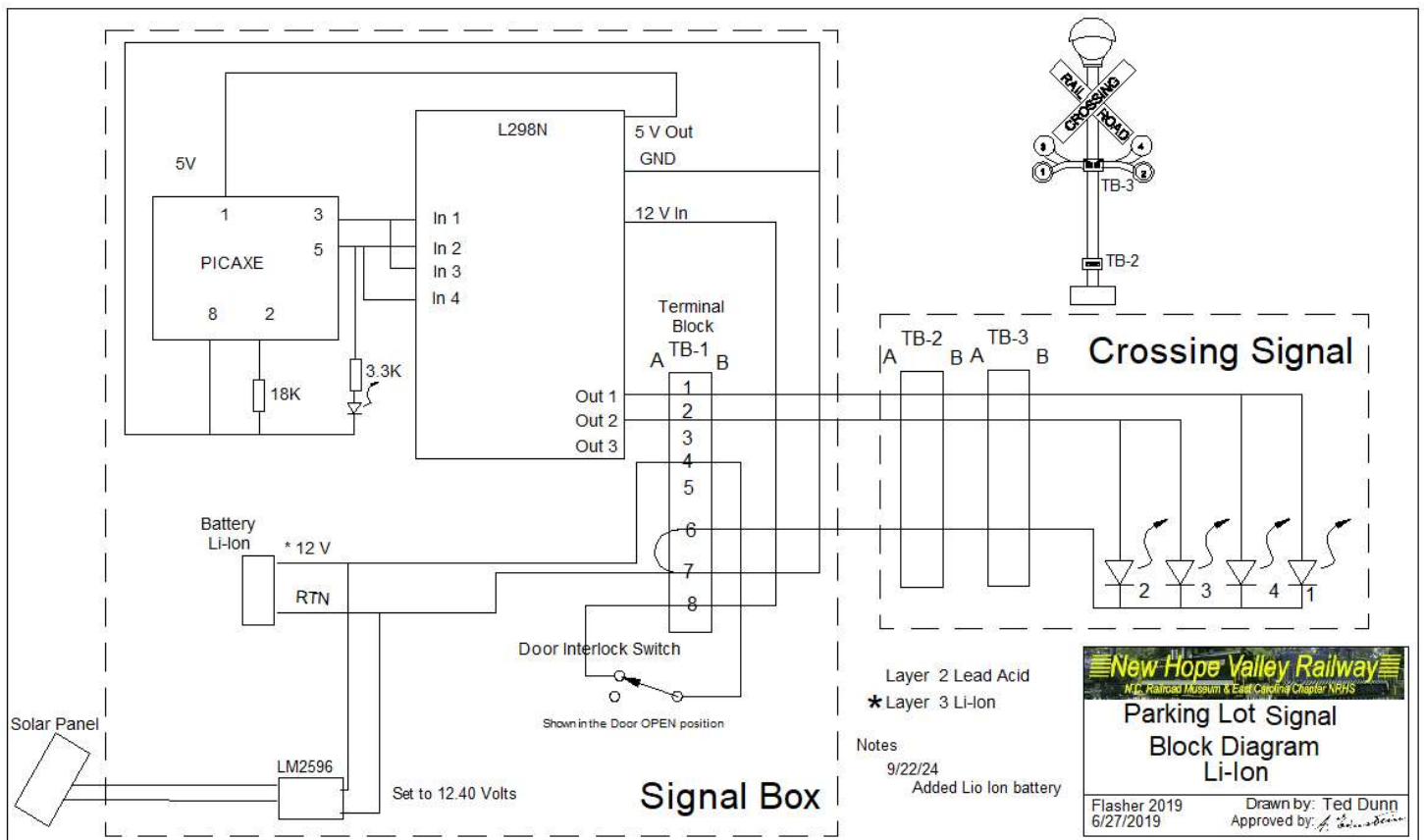

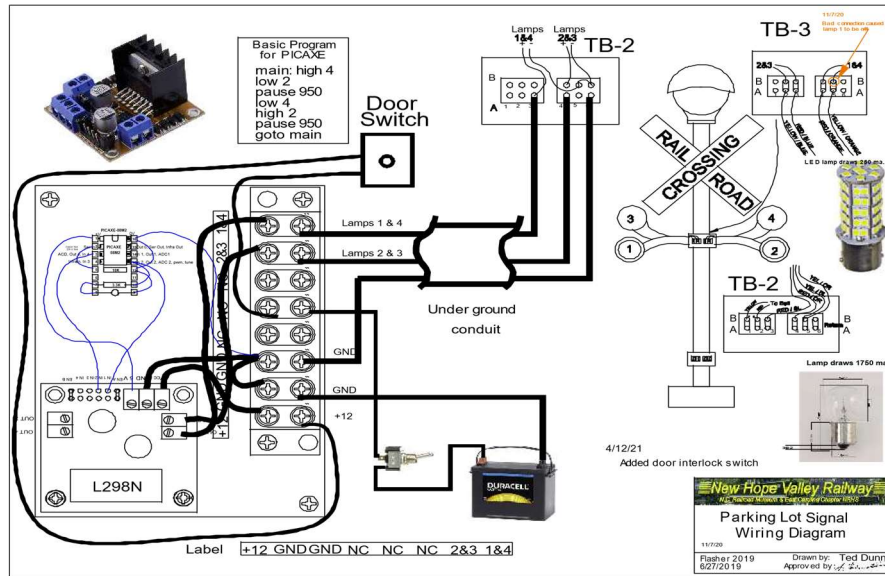

The system was modified to use a Lithium-Ion battery pack instead of the Lead Acid battery.

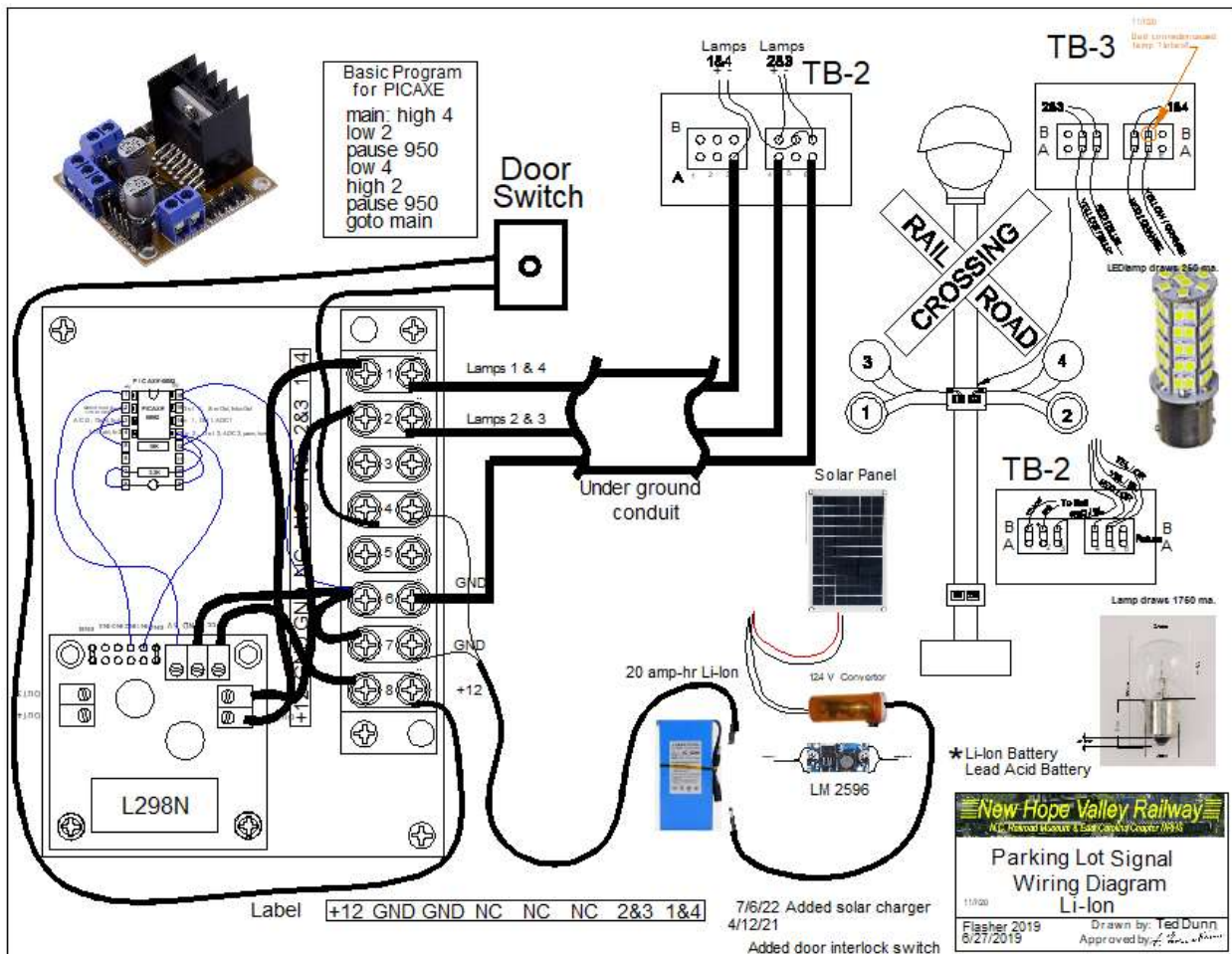



The Lithium-Ion battery, when charged with the supplied charge is fully charged at 12.8 Volts.
 For safety considerations, the LM2596 Buck Regulator was set to 12.4 Volts.
 The Solar array will supply about 20 volts unloaded.

The PICAXE is a microprocessor chip. It is used to make the timing pulses to turn the lamps on and off. The cycle time is 950 milliseconds.

The PICAXE must be programmed to make the required signals.

Basic Program for
 PICAXE

```

main: high 4
      low 2 pause
      950 low 4
      high 2 pause
      950
      go to main
  
```

The numbers
 the pin
 pin numbers

Cannot float 22K to Gnd

ACD, Out 4, In 4

Infrain, In 3

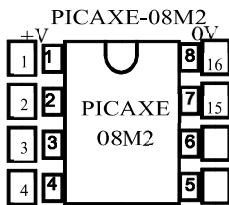

in the high and low commands above, below refer to the output index NOT number of the IC. Output 4 is pin 3 and output 2 is pin 5. The outer set of are the pins on the 16-pin socket in which the PICAX is inserted

Ser In-Out 0, Ser Out, Infra Out

14In 1, Out 1, ADC1

13In 2, Out 2, ADC 2, pwm, tune

The 18K resistor is needed to make the microprocessor stable. The 3.3K resistor and the LED are used to show that the system is on.

The L298N is a motor drive module and is used to drive the lamp. It accepts the signals from the microprocessor chip and provides the power to the lamps.

The original lamps were 10v lamps and drew 1.75 amps. These bulbs were replaced with LED replacements for automotive bulbs 1156. These LEDs draw only .25 amps.

The PICAXE requires 5 volts and by chance the L296N module has a 5 V regulator chip on board.

This provides the power for the PIXAXE microprocessor.

The circuit board is located in the signal box approximately 40 feet from the signal. Terminal

The bulbs were wired in the signal to connect lamps 1 and 3 together and lamps 2 and 4 together.

Only three wires are need to connect the signal to the signal box through the underground conduit. An LED is mounted on the circuit board header to indicate the system has been turned on.

≡ New Hope Valley Railway ≡



To the Door Switch

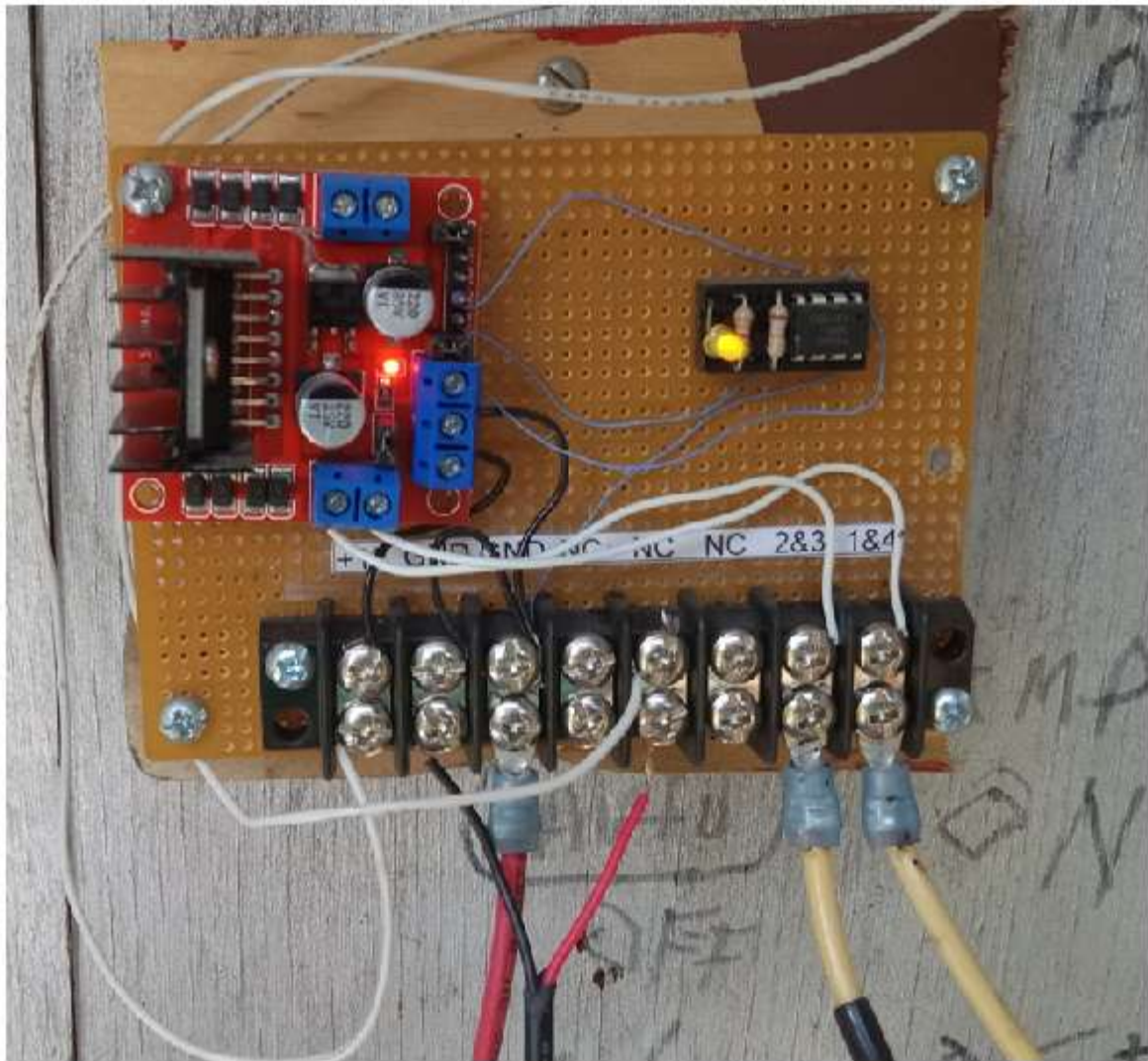

To Signal

From Battery

To Signal

